

2	All engravings modified and name	11/01/2021
1	Deco 5mm lower/bottom engraving added	6/01/2021
REV.	DESCRIPTION	DATE
REVISIONS		

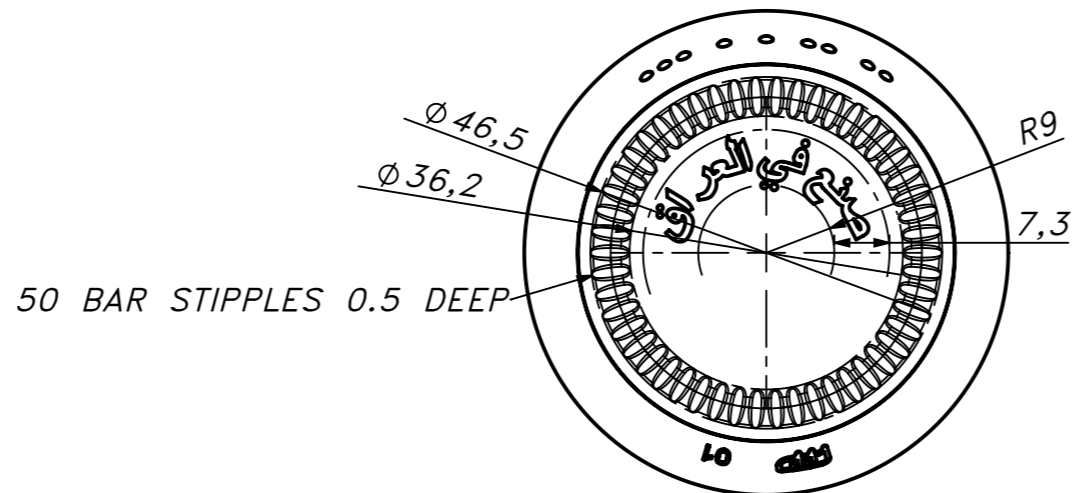
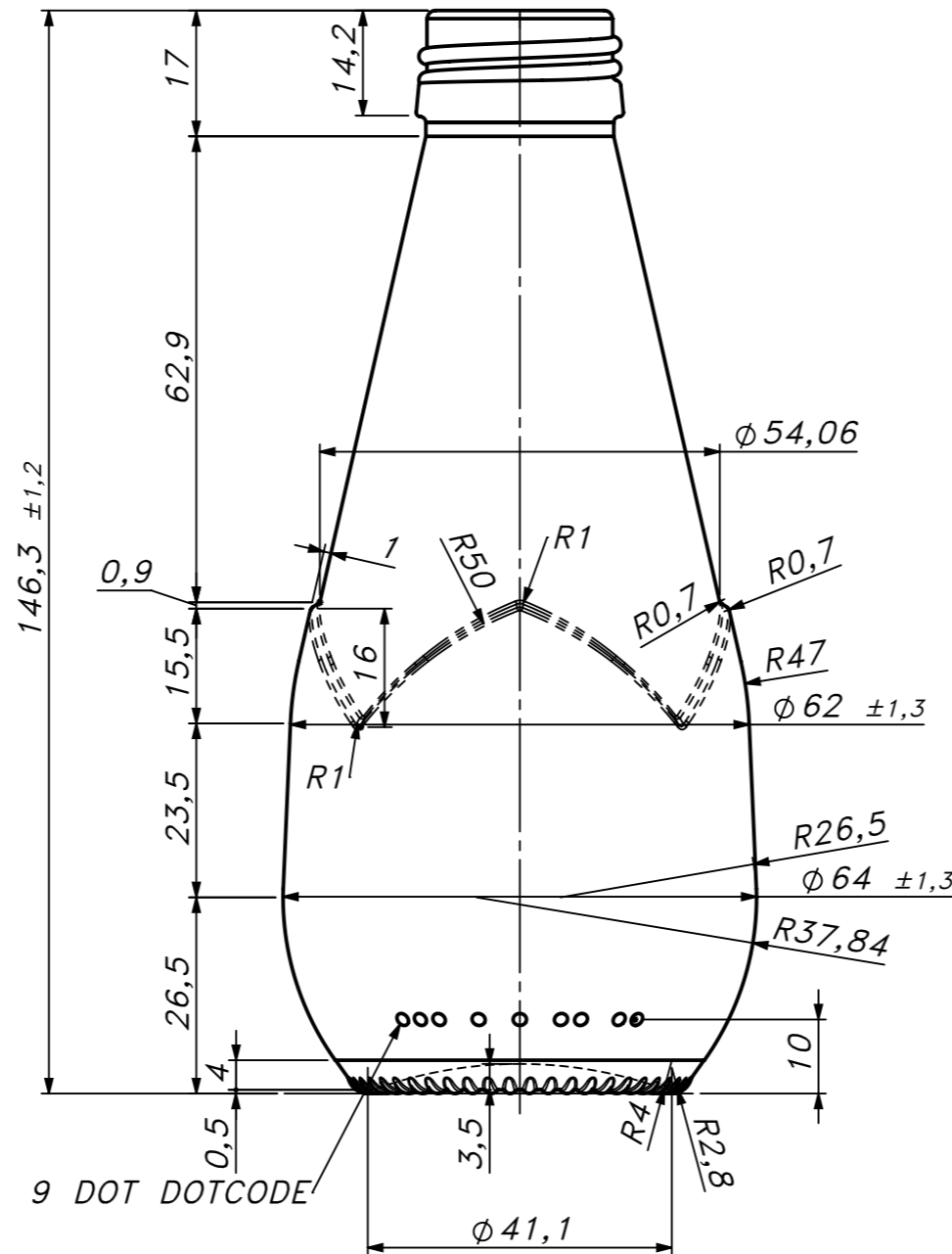
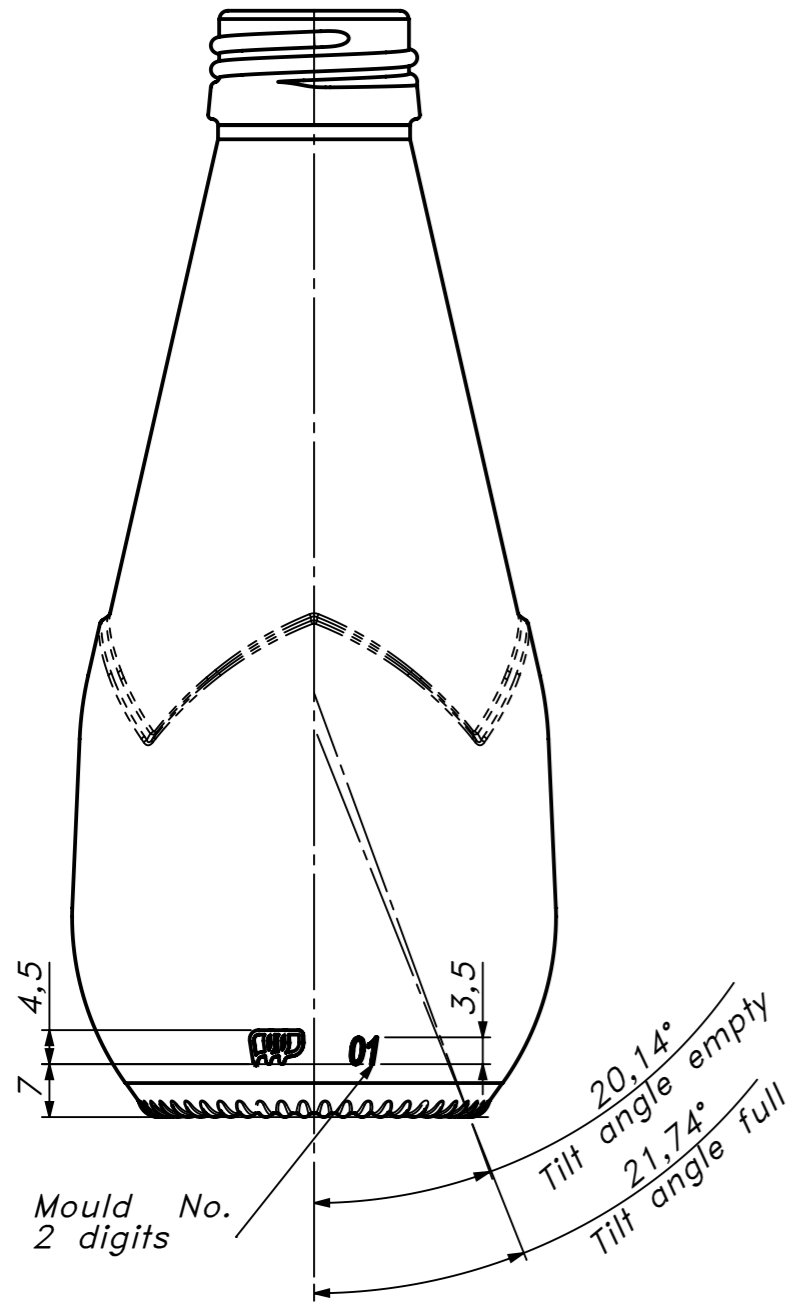

SPECIFICATIONS

FINISH	MCA-2 GF320
COLOUR	FLINT
MASS	150 gr
CAPACITY	200ml +/-6
BRIMFULL	215ml
VACUITY	7.5%
FILL HEIGHT	-
CARBONATION	-
MIN. PRESSURE	-
MAX. THERMAL SHOCK	42 °c
VERTICAL LOAD	4000N
OVALITY BODY	2.0mm
VERTICALITY (CETIE DT_2)	1.8mm
STABILITY RATIO (CETIE DT_3)	0.28
SHOULDER IMPACT	min. 76 cm/s
HEEL IMPACT	min. 76 cm/s
PROCESS	BB
MOULD No.	A20039
RING REF.	TT 1111

MINIMUM WALL THICKNESS

SHOULDER CONTACT	1.4mm
MID BODY	1.4mm
HEEL CONTACT	1.4mm

MINIMUM BOTTOM THICKNESS

BEARING SURFACE	2
-----------------	---

NON RETURNABLE

THIS DRAWING REMAINS THE PROPERTY OF APEGG AND SHOULD NOT BE COPIED IN PART OR WHOLE WITHOUT PRIOR WRITTEN AGREEMENT.	Copyright © APEGG LTD.	
TOLERANCED SIZES ARE FOR CONTAINER CONTROL. CONSTRUCTION SIZES ARE FOR MOULD MAKING PURPOSES. CAPACITY TOLERANCE APPLIES TO BULK TEST MEAN OF 12 OR MEAN RANGE METHOD FOR MEASURING CONTAINERS. FILL LINE IS MEASURED CENTRALLY INSIDE FROM TOP OF BOTTLE.	DRG. No.: A20039-01-03	
	DRN. BY: JBB	CHK. BY
	DATE: 29/12/20	SCALE: 1:1

Copyright © APEGG LTD.

PROPOSAL No. 3

ITEM: BOTTLE DRAWING

TITLE: 200ml 7 STARS

Design proposal subject to sampling