

Cutter  $\Phi 12,5$   
Pitch 3,63  
Cutter angle  $2^\circ 16'$   
Scale 5:1

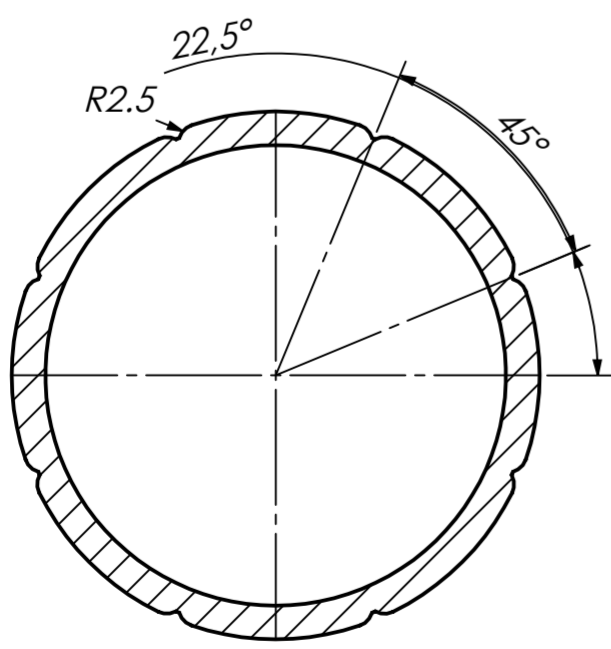
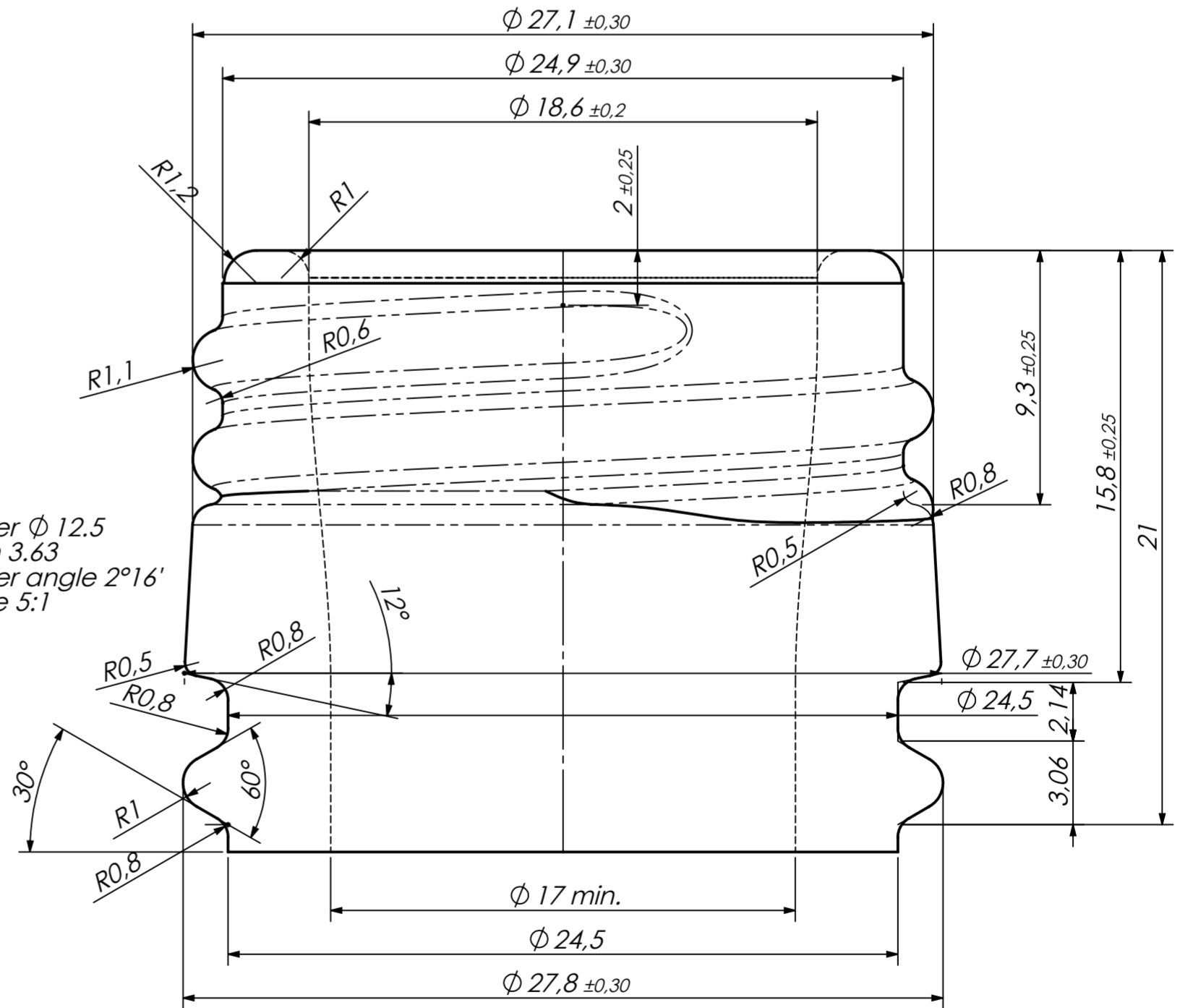

B-B

APPROVED  
07/03/2012

Rev A 07/03 engraving removed from base to heel

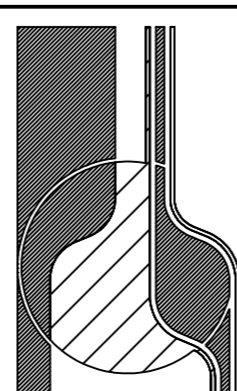

BIEBOUW B.V.BA.  
INDUSTRIESTRAAT 17  
B-8755 Ruiselede  
Belgium  
Tel.: +32(0)51 686714  
Fax.: +32(0)51 689182  
Email: info@biebouw.com

JOB NAME	250ML Gallon Bottle		
CUSTOMER	Modern Co.		
FILLING	250ml -/+6	PROCESS	Emhart BB DG 5'
BRIMFULL	265ml -/+6	DRAWN BY	JBB
WEIGHT	250gr +/-10	CHECKED BY	-
FINISH	CETIE 30.06 PP28	DATE	3/02/2015
DRG. NO. BIEB420-01 A			