

A-A

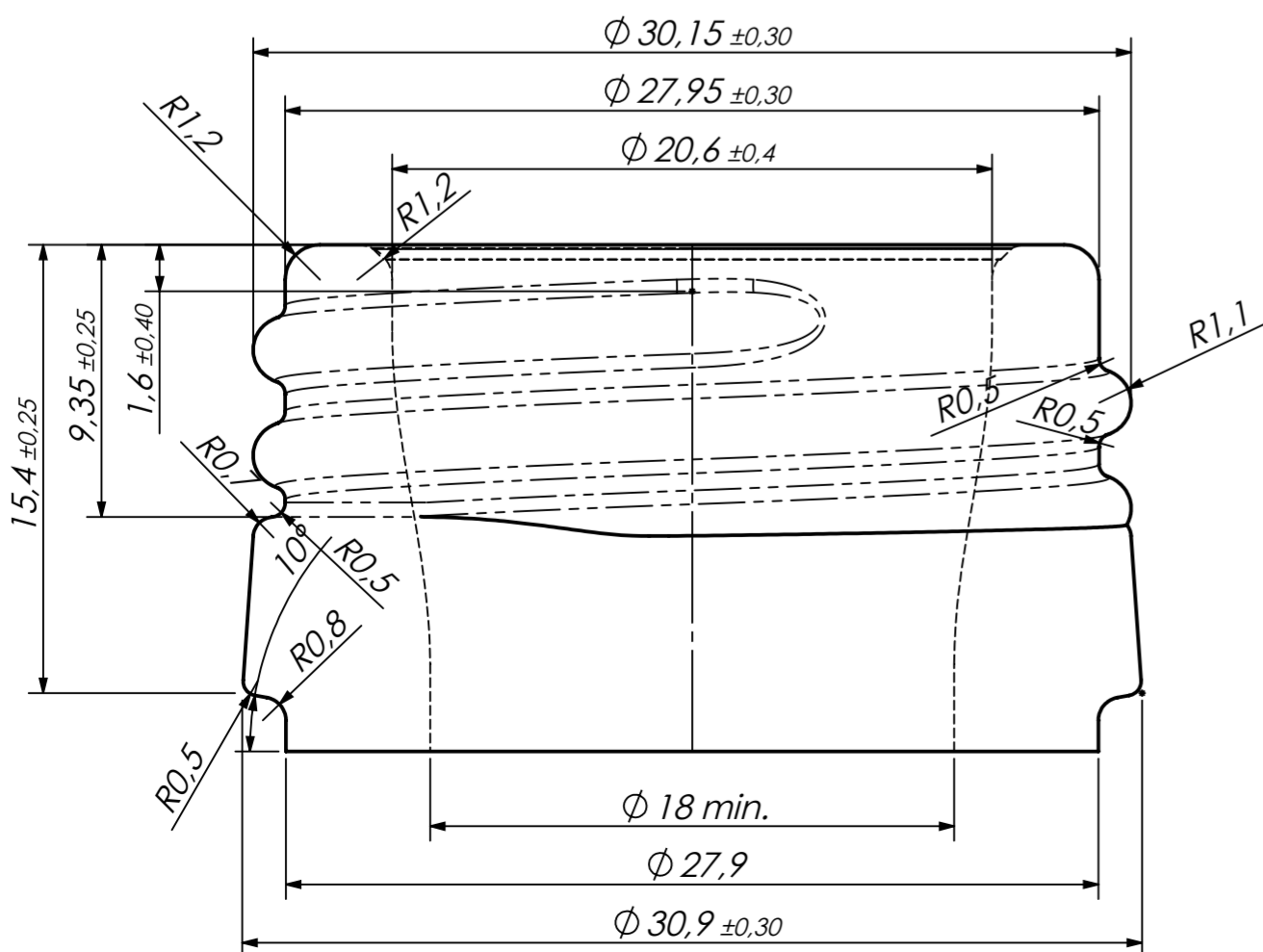

Cutter diameter 12.5  
Pitch 3.63

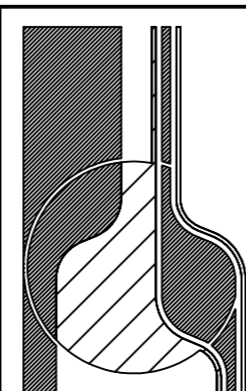
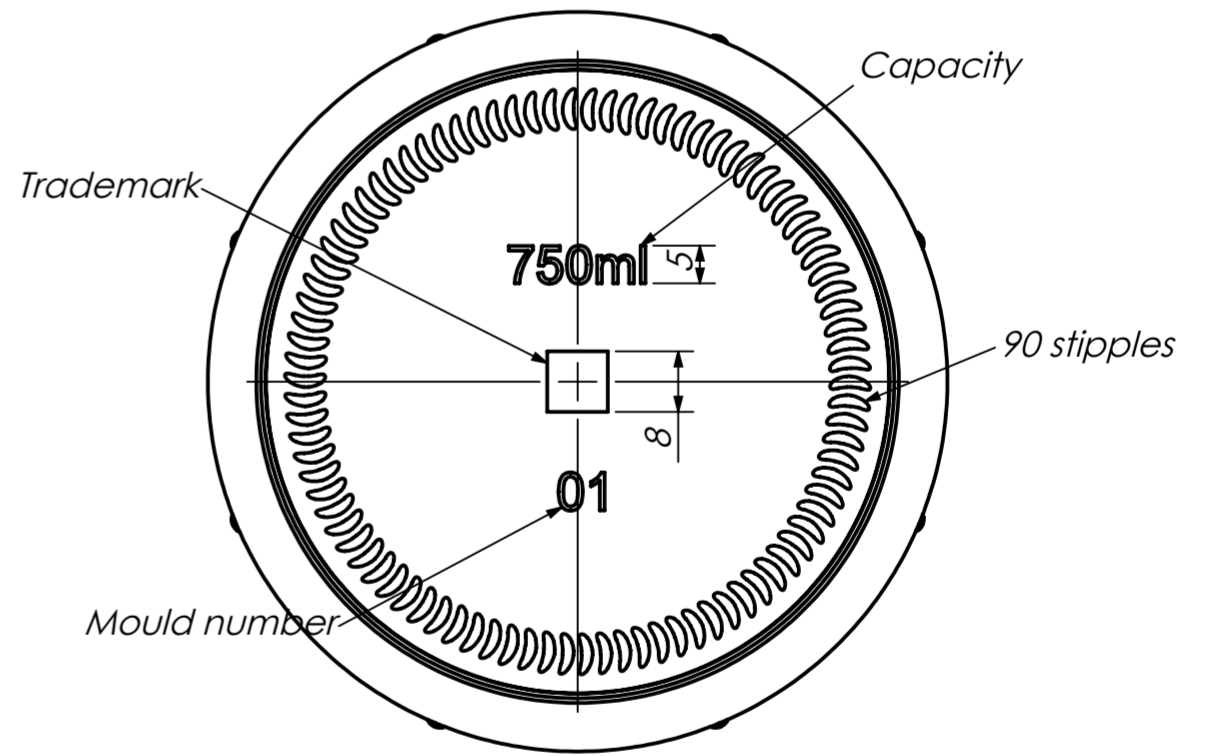

BIEBOUW B.V.B.A.  
INDUSTRIESTRAAT 17  
B-8755 Ruiselede  
Belgium

Tel.: +32(0)51 686714  
Fax.: +32(0)51 689182  
Email: info@biebouw.com

JOB NAME	750ML OIL Bottle		
CUSTOMER	Raslan		
FILLING	750ml	PROCESS	-
BRIMFULL	770ml -/+10	DRAWN BY	JBB
WEIGHT	550gr +/-25	CHECKED BY	-
FINISH	31.5Std PP Din 6094	DATE	30/06/2010
DRG. NO. BIEB341-01			