

Front view
Scale: 1:1

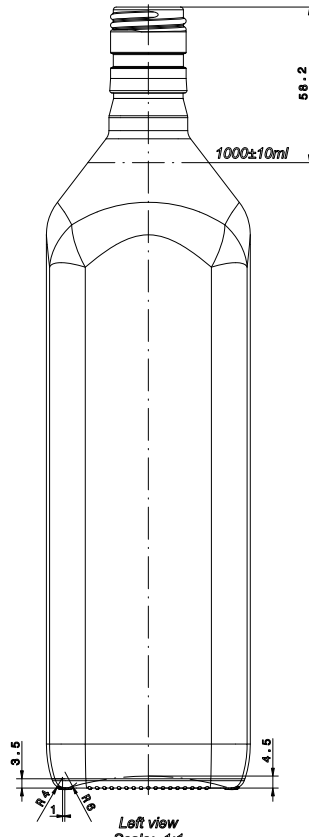

Left view
Scale: 1:1

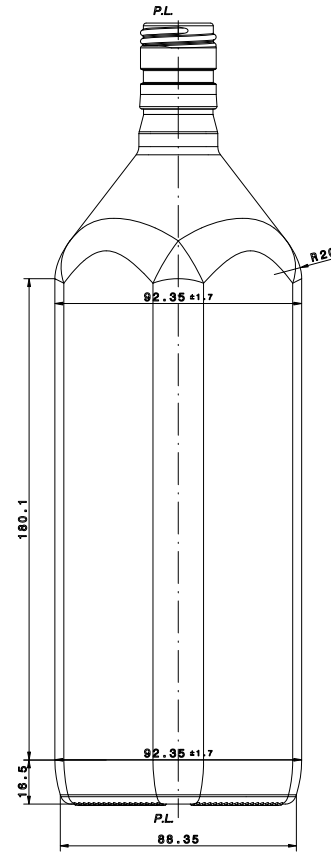

View through parting line

FINISH TYPE :
GF 305

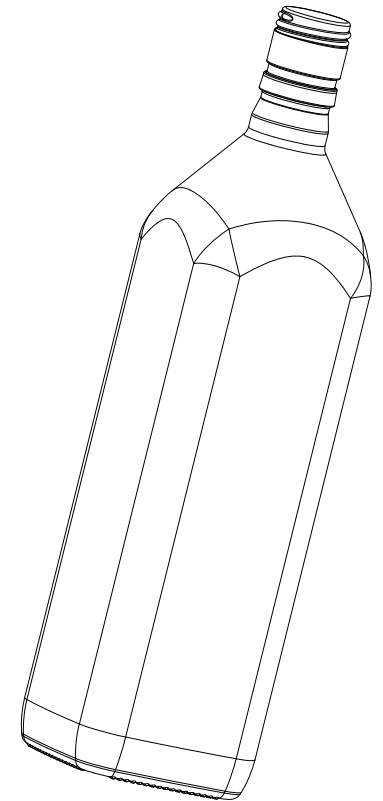

Isometric view
Scale: 1:1

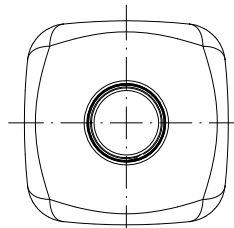
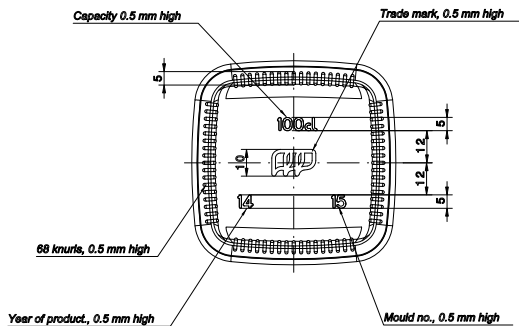

Top view
Scale: 1:1

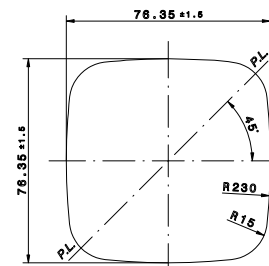

Section cut A-A
Scale: 1:1

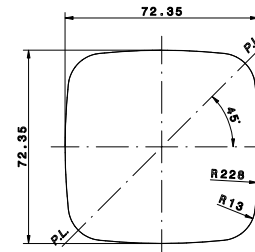

Section cut B-B
Scale: 1:1

Tip angle - 15.8°

CAPACITY LEVEL FULL		WEIGHT		DESIGNER	DATE	FINISH #1	WALL	NOTE: DO NOT SCALE
1023	ML	555	GRM	Krklec I.	07.01.14.		3.5mm	<small>1 DIMENSIONS SHOW GLASS BODIL UNTOUCHED DIMENSIONS ARE NOT SUBJECT TO PROFORMA LISTS 2 FILLING POINT MEASURED FROM TOP CENTRALLY BESE. 3 CAPACITY TOLERANCE APPLIES TO BULK TEST MEAN OF 15.</small>
CAPACITY AT FILL LINE		GLASS COLOUR		Job. No.				
1000 ± 10	ML	FLINT		K00309				
FILL LINE	59	FROM TOP	REF. No.	TITLE		SQUARE BOTTLE 1000ml		DRG.No. K00309-SPE-01-3
VACUITY	7.7%							