

Finish type: TO30 Medium FD 169

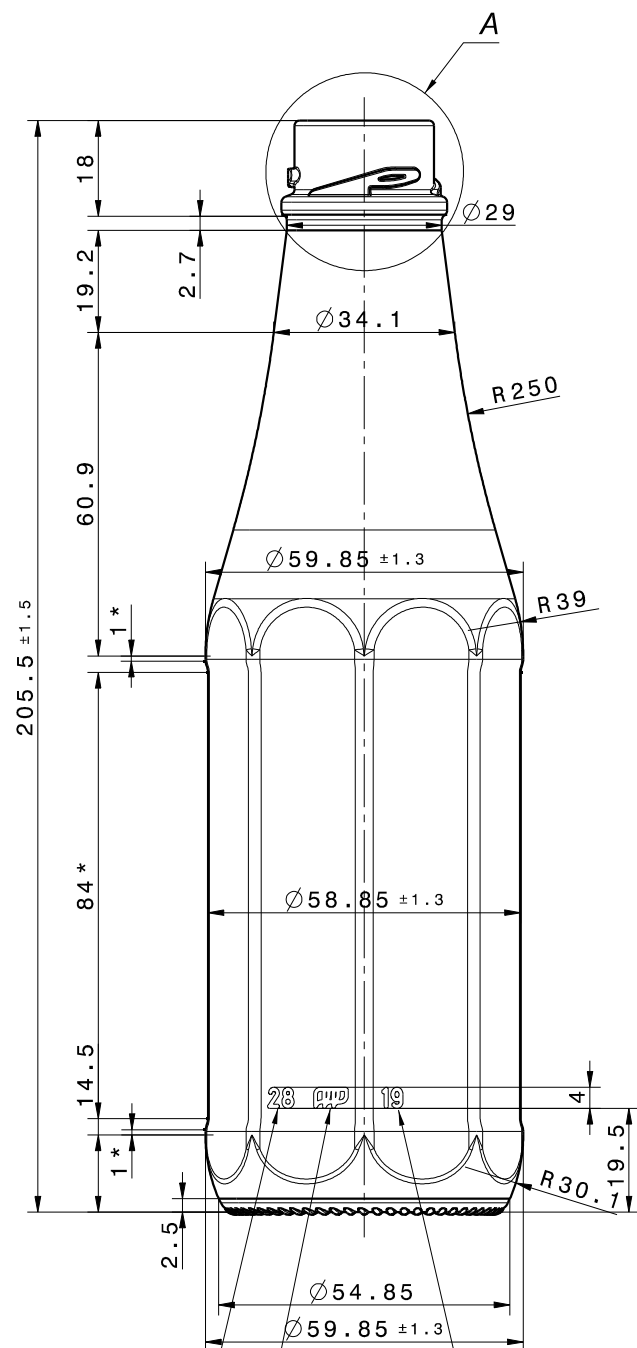

Front view  
Scale: 1:1

Broj kalupa, 0.3 mm izbočeno  
Mould no., 0.3 mm high

Tvornički znak, 0.3 mm izbočeno  
Trade mark, 0.3 mm high

Godina proizvodnje, 0.3 mm izbočeno  
Year of production, 0.3 mm high

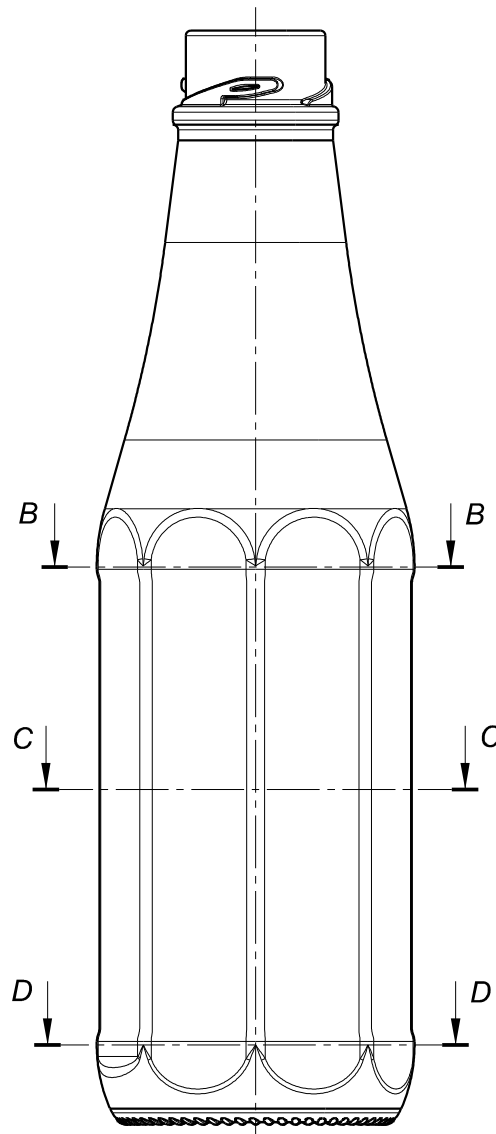

Left view  
Scale: 1:1

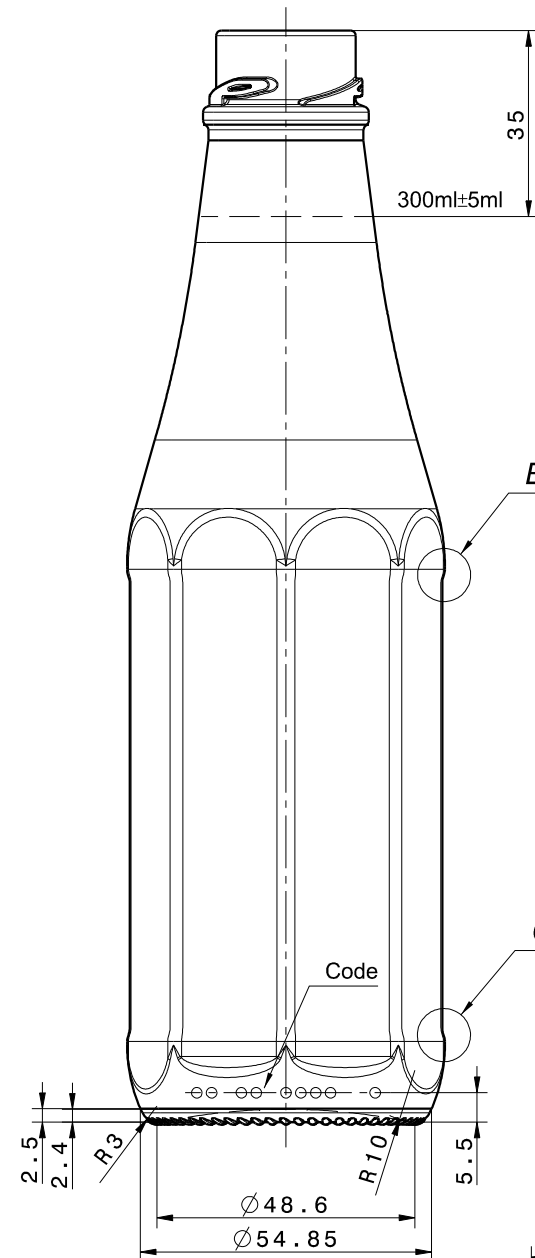

Rear view  
Scale: 1:1

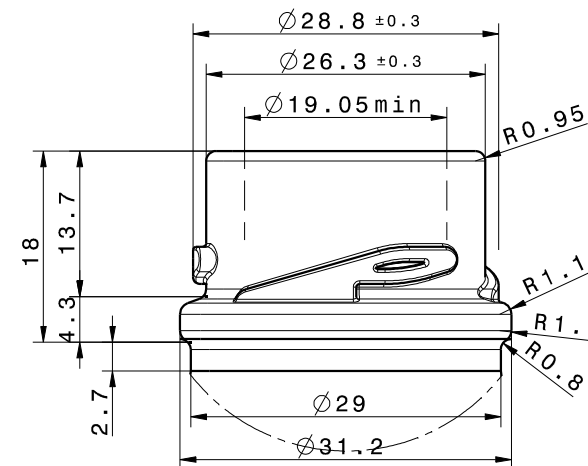

Detail A  
Scale: 2:1

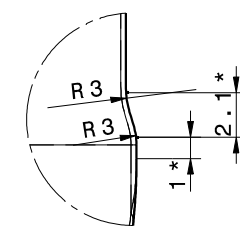

Detail C  
Scale: 4:1

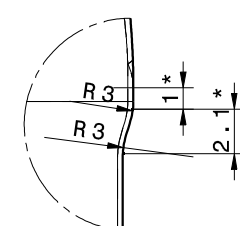

Detail B  
Scale: 4:1

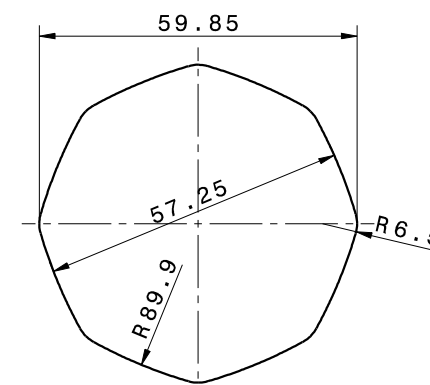

Section cut D-D  
Scale: 1:1

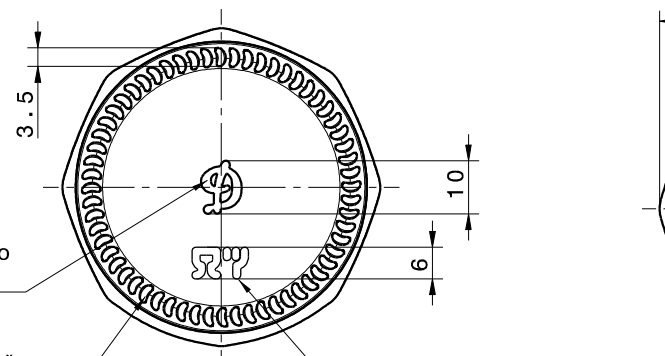

Bottom view  
Scale: 1:1

Engraving, 0.5mm izbočeno  
Engraving, 0.5mm high

60 recki, 0.5mm izbočeno  
60 knurls, 0.5mm high

TZ-VL103.PLT, 0.5mm izbočeno

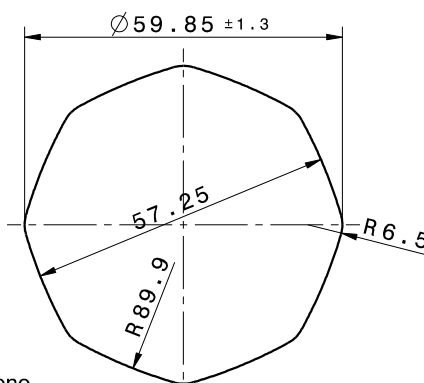

Section cut B-B  
Scale: 1:1

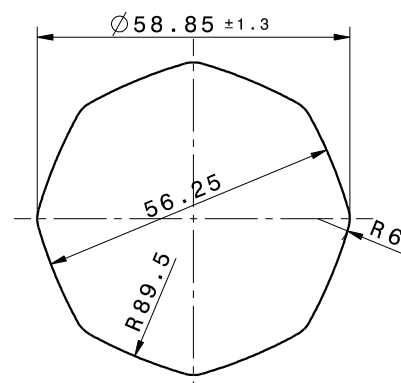

Section cut C-C  
Scale: 1:1

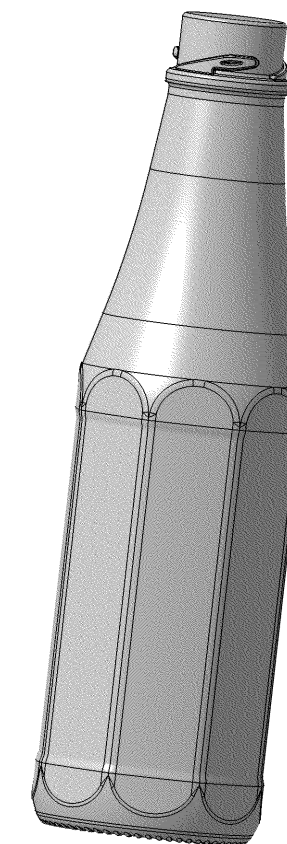

Isometric view  
Scale: 3:4

		ARTIKAL			Poz.	Materijal	Dimenzija
		Kom.	Naziv dijela				
			Datum	Ime i prezime			
		Konstruirao	20.09.18.	Zajec T.			
		Crtao	20.09.18.	Zajec T.			
		Pregledao	20.09.18.	KRKLEC			
		Naziv:		KETCHUP 300ml			
		Sadržaj:		300ml (do vrha 313 ± 5ml)			
b	Promjena težine: 225g-->220g	07.12.18.	Zajec T.	Težina:	220g ± 10 g		
a	Promjena grla: FD 145D -->FD 169	06.12.18.	Zajec T.	Proces:	puhano - puhano (BB)		Kupac: MODERN COMPANY
Index	Revizija	Datum	Izmijenio	Mjerilo:	1:1		Broj nacrt: 00-00

\*- Construction dimension