

Finish type: DIN 6094 31.5 Standard

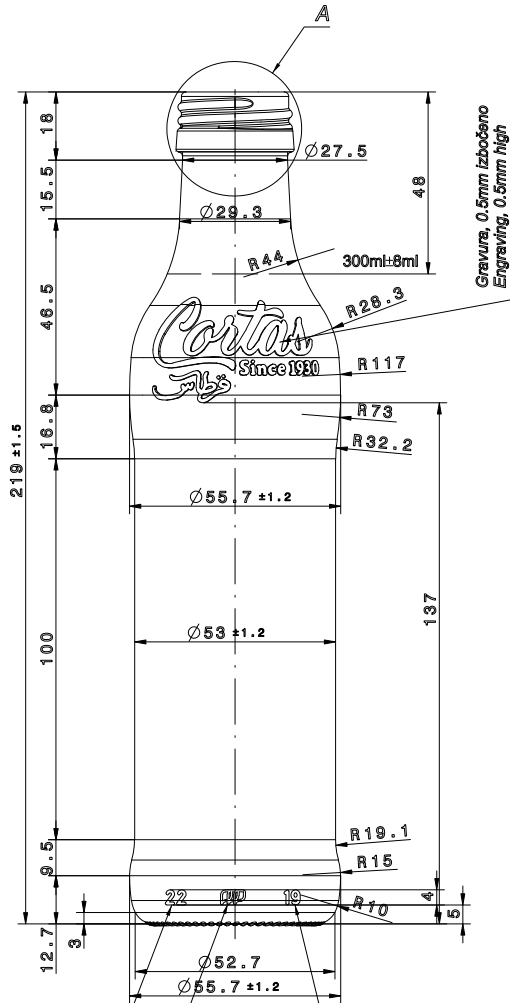

Gravura, 0.5mm izbočeno  
Engraving, 0.5mm high

Broj kalupa, 0.3 mm izbočeno  
Mould no., 0.3 mm high

Tvornički znak, 0.3 mm izbočeno  
Trade mark, 0.3 mm high

Front view  
Scale: 1:1

Godina proizvodnje, 0.3 mm izbočeno  
Year of production, 0.3 mm high

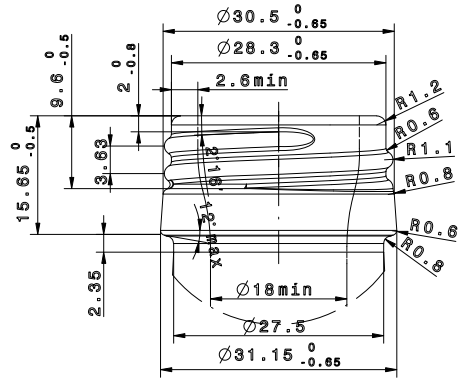

Detail A  
Scale: 2:1

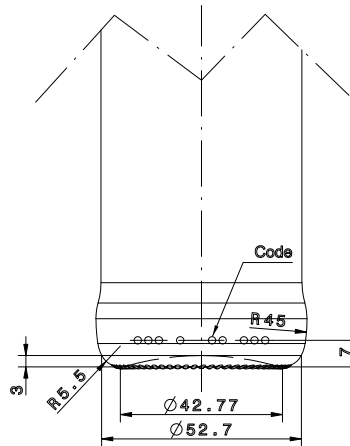

Rear view  
Scale: 1:1

TZ-VL107.PLT

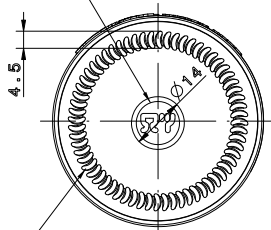

64 rečki, 0.5 mm izbočeno  
64 knurls, 0.5 mm high

Bottom view  
Scale: 1:1



Developed engraving  
Scale: 2:1



Isometric view  
Scale: 1:1

		ARTIKAL			
Kom.	Naziv dijela	Poz.	Materijal	Dimenzija	
	Datum	Ime i prezime			
	Konuirano	Zajec T.			
	Crtao	Zajec T.			
	Pregledao	KRGLEC			
Naziv:		CORTAS-2 300ml			
Sadržaj:		300ml (do vrha 330 ±8ml)			
b	Changed heel engraving	07.11.18.	Zajec T.	Težina:	216g
a	Added bottom engraving	25.10.18.	Zajec T.	Proces:	puhano - puhano (BB)
Index	Revizija	Datum	Izmijenio	Mjerilo:	1:1
				Kupac:	MODERN COMPANY
				Broj narudb:	00-00