

Front view
Scale: 1:1

Broj kalupa, 0.3 mm izbočeno
Mould no., 0.3 mm high

Tvornički znak, 0.3 mm izbočeno
Trade mark, 0.3 mm high

Godina proizvodnje, 0.3 mm izbočeno
Year of production, 0.3 mm high

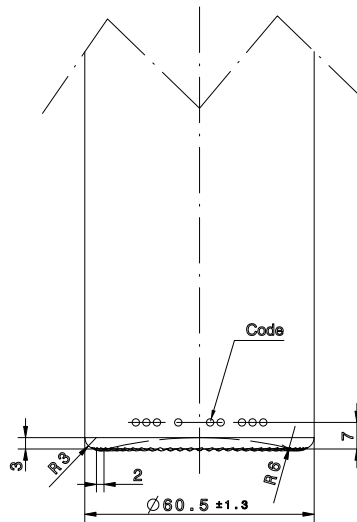

Rear view
Scale: 1:1

Finish type: DIN 6094 31.5 Standard

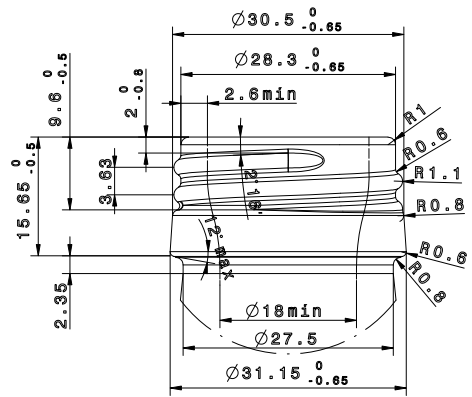

Detail A
Scale: 2:1

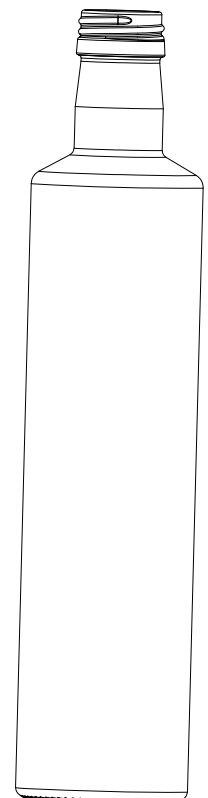

Isometric view
Scale: 3:4

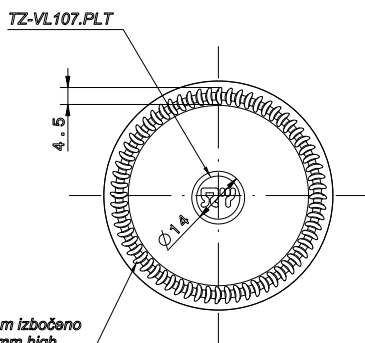

Bottom view
Scale: 1:1

64 rečki, 0.5 mm izbočeno
64 knuris, 0.5 mm high

				ARTIKAL					
		Kom.	Naziv dijela		Poz.	Materijal	Dimenzija		
		Datum		Ime i prezime					
			18.09.18.	Zajec T.					
			18.09.18.	Zajec T.					
			18.09.18.	KRKLEC					
		Naziv: DORICA 800ml							
		Sadržaj: 800ml (do vrha 625 ±10ml)							
b	Changed heel engraving	07.11.18.	Zajec T.	Težina: 370g					
a	Added bottom engraving	25.10.18.	Zajec T.	Proces: puhanu - puhanu (BB)			Kupac: MODERN COMPANY		
Index	Revizija		Datum	Izmjenio	Mjerilo: 1:1		Broj nacrt: 00-00		