

Finish type. DIN 6094 31.5 Standard

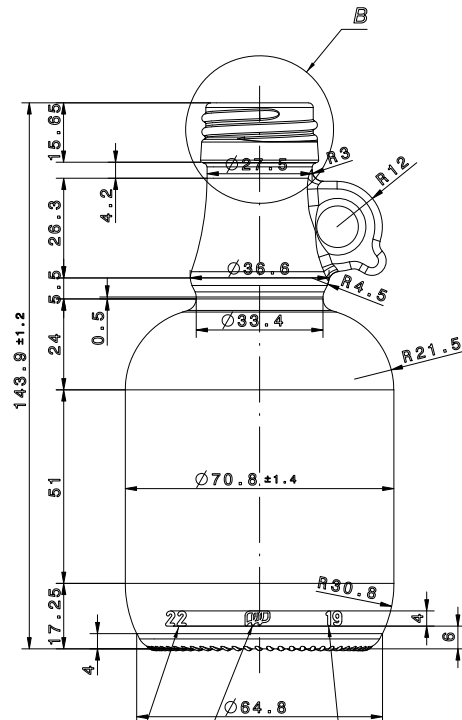

Broj kalupe, 0.3 mm izbočeno
Mould no., 0.3 mm high

Tvornički znak, 0.3 mm izbočeno
Trade mark, 0.3 mm high

Godina proizvodnje, 0.3 mm izbočeno
Year of production, 0.3 mm high

Front view
Scale: 1:1

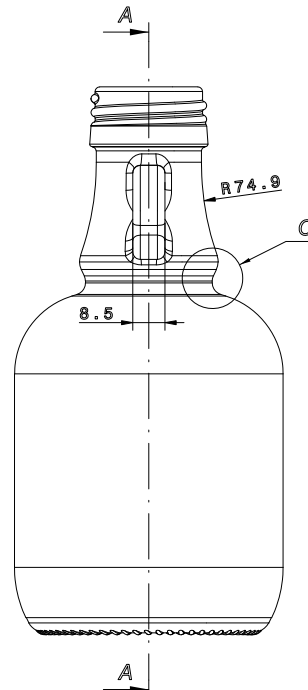

Right view
Scale: 1:1

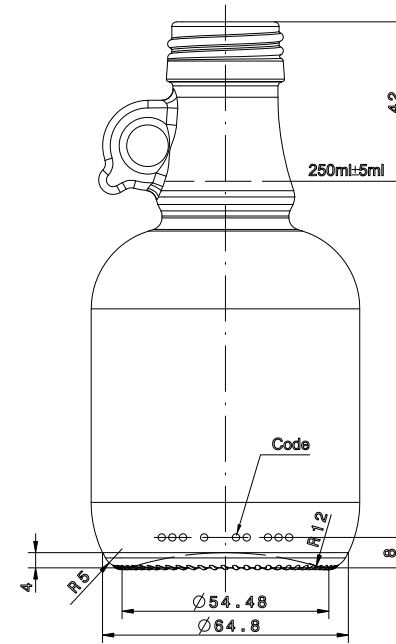

Rear view
Scale: 1:1

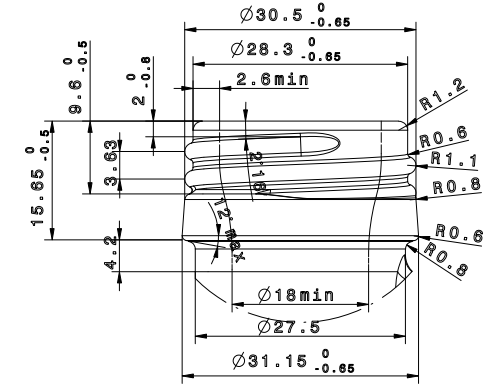

Detail B
Scale: 2:1

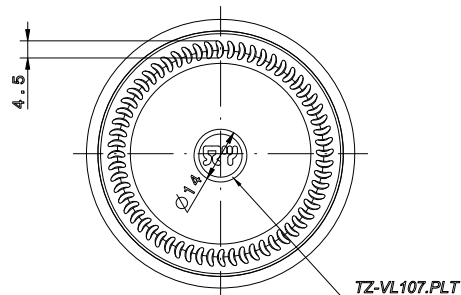

Bottom view
Scale: 1:1

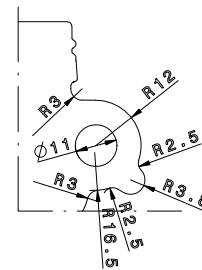

Section cut A-A
Scale: 1:1

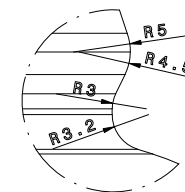

Detail C
Scale: 3:1



Isometric view
Scale: 1:1

		ARTIKAL						
		Kom.	Naziv dijela		Poz.	Material	Dimenzija	
		Datum		Ime i prezime				
			20.09.18.	Zajec T.				
			20.09.18.	Zajec T.				
			20.09.18.	KIKLEC				
			Naziv: KOBAYTON 250ml					
			Sadržaj: 250ml (do vrha 250 ± 8ml)					
b	Promjena gravure u peti	07.11.18.	Zajec T.	Težina: 255g ± 10 g				
a	Promjena gravure na dnu	25.10.18.	Zajec T.	Proces:	puhano - puhano (BB)	Kupac:	MODERN COMPANY	
Index	Revizija	Datum	Izmijenio	Mjerilo:	1:1	Broj nacrt:	00-00	