

9 DOT CODE

120CRECENT STIPPLE
KNURL 4mm×0,4DEEP

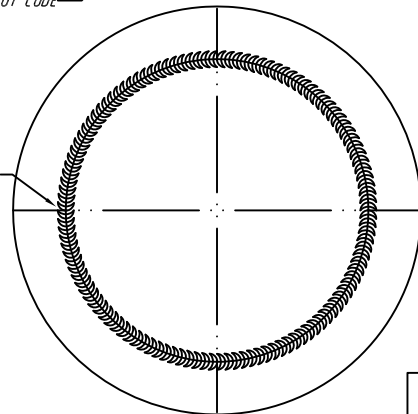

ALL DIMENSIONS ARE IN MILLIMETERS

M.C.G.I

| | | | |
|----------|------------------------------|------------|------------|
| JOB NAME | JAR 980ML (FINISH TO 66) | | |
| CUSTOMER | CORTAS | | |
| FILLING | PROCESS | P-B | |
| BRIMFULL | 980ML ± 10ML | DRAWN BY | M.S |
| WEIGHT | 400GR ± 10GR | CHECKED BY | |
| FINISH | HELIX TO66 DEEP FD 138 B (8) | DATE | 08.05.2012 |
| DRG. NO. | 310 | | |