

Finish type: GPI 2030 - SIZE 70

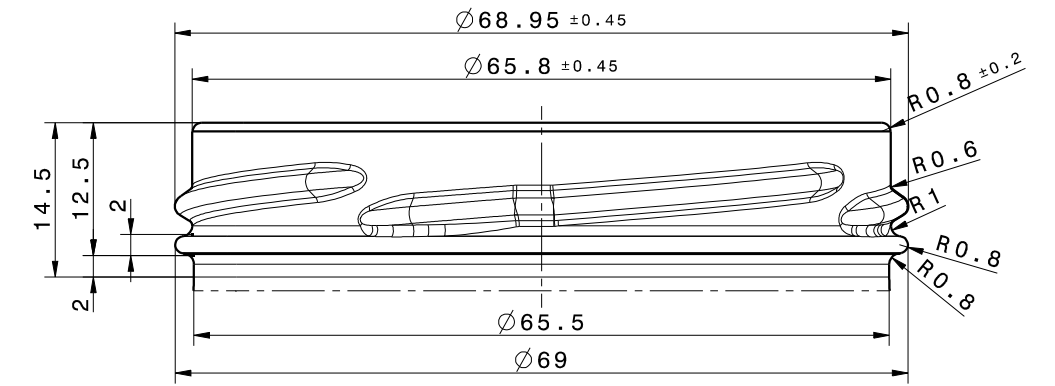

Detalj A
M 2:1



Isometric view
Scale: 1:1

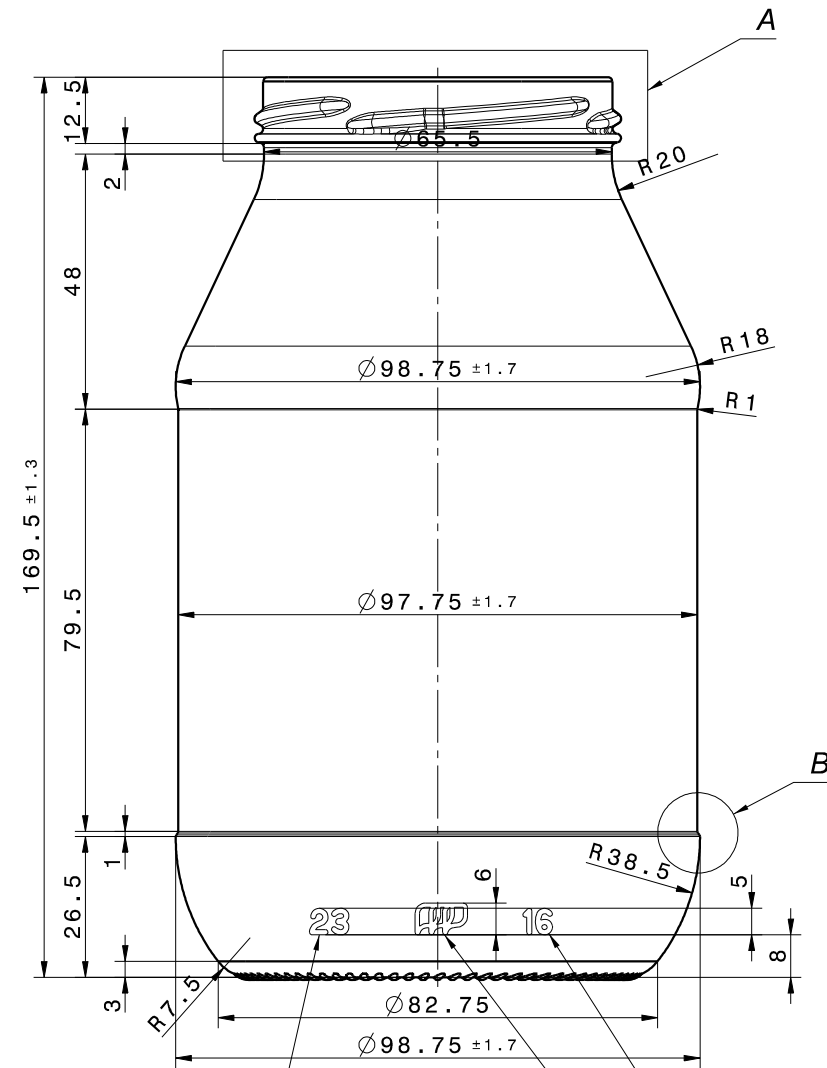

Front view
Scale: 1:1

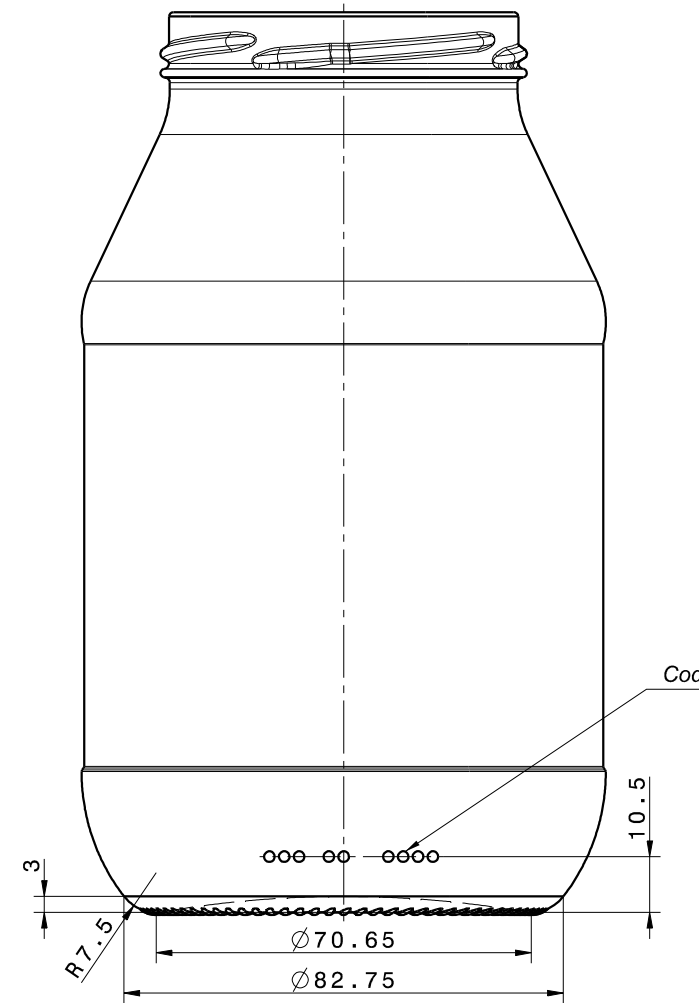

Left view
Scale: 1:1

Broj kalupa, 0.3 mm izbočeno
Mould no., 0.3 mm high

Godina proizvodnje, 0.3 mm izbočeno
Year of production, 0.3 mm high

Tvornički znak, 0.3 mm izbočeno
Trade mark, 0.3 mm high

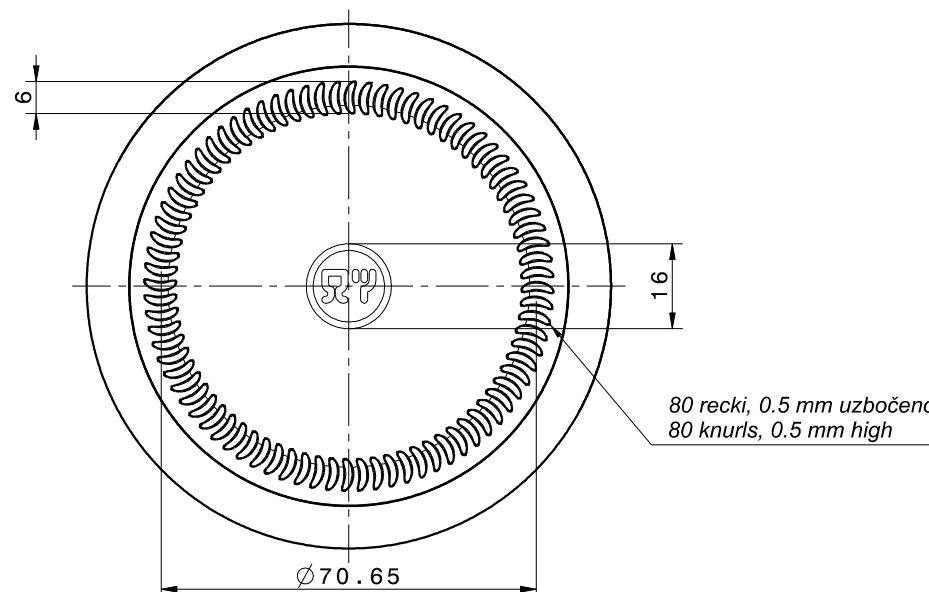

Bottom view
Scale: 1:1

80 recki, 0.5 mm uzbočeno
80 knurls, 0.5 mm high

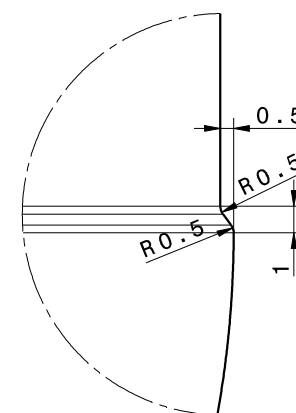

Detalj B
M 5:1

		ARTIKAL				
Kom.	Naziv dijela	Poz.	Materijal	Dimenzija		
		Datum	Ime i prezime			
Konstruirao	04.11.15.	Frljužec K.				
Crtao	04.11.15.	Frljužec K.				
Pregledao	04.11.15.	TEPEŠ				
Naziv:	MAYONNAISE JAR 940ml					
Sadržaj:	940ml (do vrha 945 ± 15 ml)					
Težina:	372g					
Proces:	puhano - puhano (BB)			Kupac:	MODERN COMPANY	
Index	Revizija	Datum	Izmjenio	Mjerilo:	1:1	Broj nacrt: 00-00